

电机参数	类型Type	DC	伺服电机Servo motor	
	负载Load	kg	1500	3000
	电机品牌Motor brand	HKT		
	电机型号Motor type			
	电机型号Motor type			
	驱动器型号Driver type			
	驱动器型号Driver type			
	电机功率Motor power	W	750	1500
	电机电压Motor voltage	V	48	48
	电机转速Motor speed	Rpm	3000	3000
	电机电流Motor current	A	19	30
	额定转矩Rated Torque	Nm	2.39	4
	防护等级Protection level	IP	65	65
	编码器Encoder	磁编	增量	增量
编码器Encoder	分辨率	2500	2500	

升降参数	类型Type	X	行星减速机Planetary reducer	
	行程Route	mm	90	90
	丝杆规格Screw rod specification	mm	T45x6	T45x6
	减速机速比Speed ratio of reducer	i	40	40
	传动齿比Gearratio	i	5.3	5.3
	升降速度Up and down speed	mm/s	7.5	7.5
	升降时间Up and down time	s	13.30	13.30
	限位传感器Limit Sensor	必得客	常开NPN	常开NPN

旋转参数	类型Type	X	行星减速机Planetary reducer	
	减速机速比Speed ratio of reducer	i	40	40
	传动齿比Gearratio	i	7.7	7.7
	旋转速度Rotation per second	°	58.4	58.4
	旋转90°Rotation 90°	s	1.54	1.54
	旋转原点Origin of rotation	必得客	常开NPN	常开NPN

其他	减速机润滑Reducer lubrication	润滑油	-20°~200°	
	自重Self weight	kg	150	
	应用次数Number of applications	大于30万次		

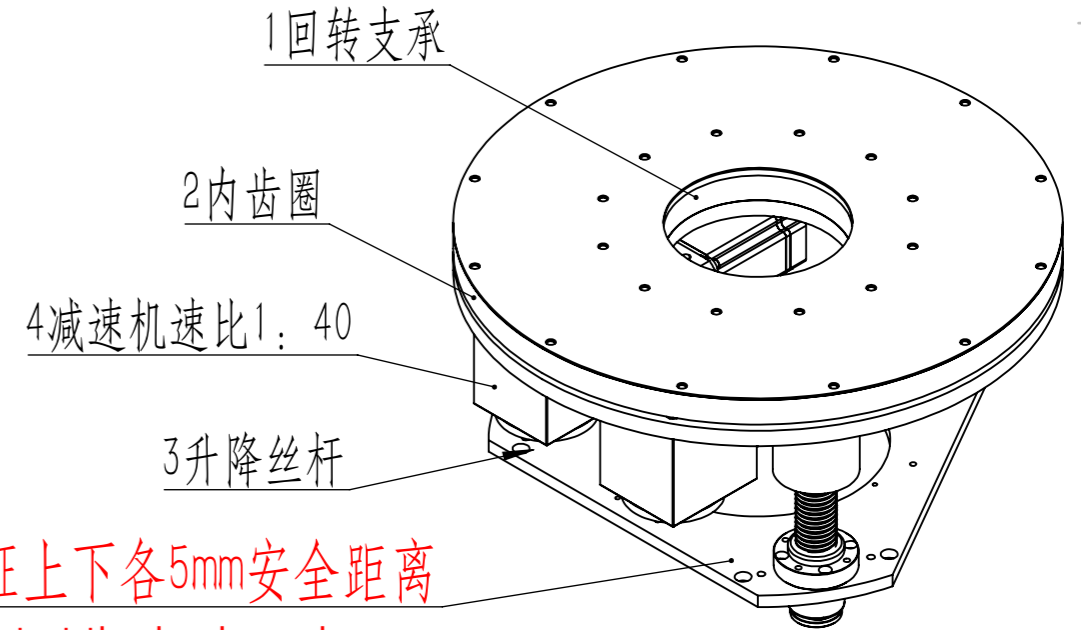
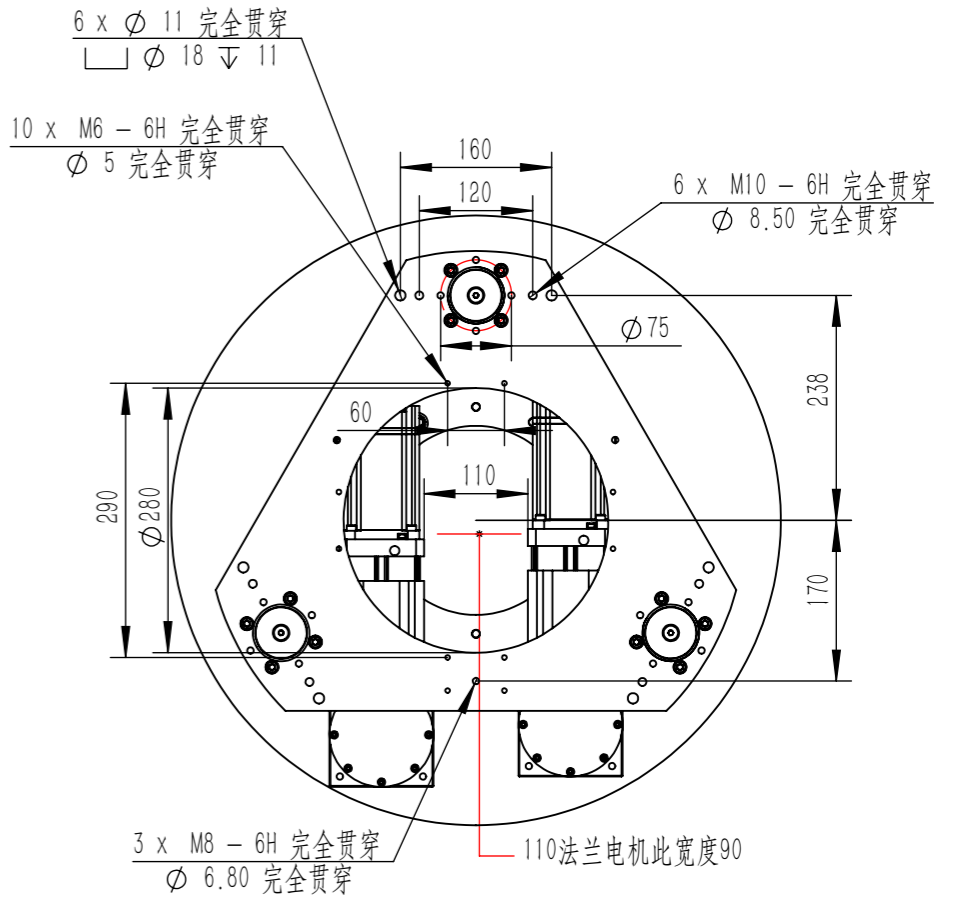
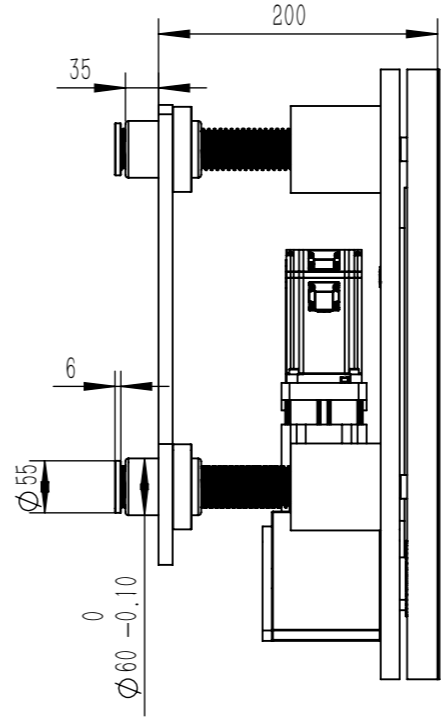
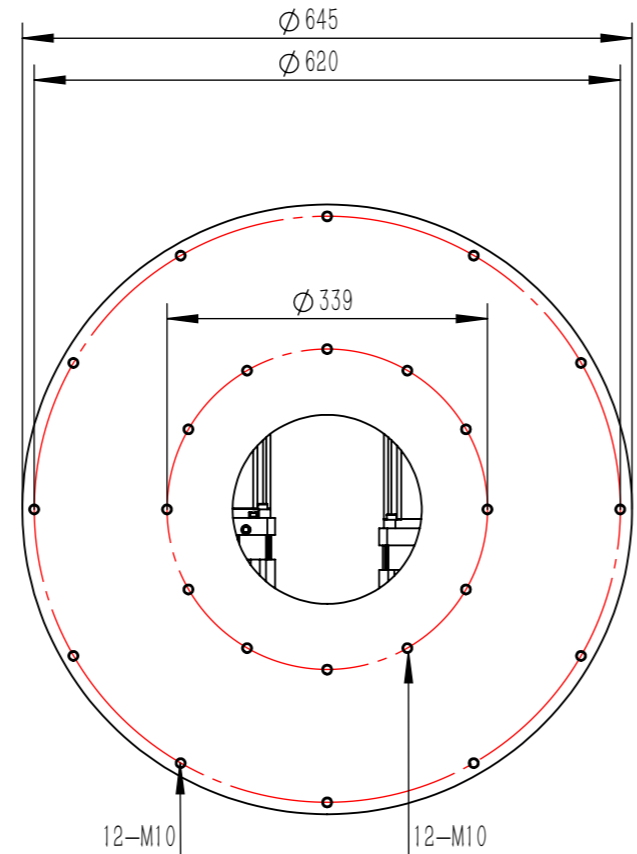

车体端保证安装平面度及丝杆螺母同心度
丝杆总行程100mm,有效行程90mm.调试务必保证上下各5mm安全距离

Ensure installation flatness and concentricity of screw nut at the body end
The total screw stroke is 100mm. The effective stroke is 90mm. During debugging, ensure a safety distance of 5mm up and down

1.5-3T Lifting and rotating mechanism

标记	处数	分区	更改文件号	签名	年月日	阶段标记	重量	比例	HKT-ROBOT
设计			标准化				43.528	1:8	
校核			工艺						
主管设计			审核						
			批准			共1张 第1张 版本			Model:HKT-DSXZ-1.5-3T-90
									Shenzhen Hengketong Robot Co., Ltd.